

Keil-Flachschieber PN 10/16

Sphäroguss/Edelstahl, DIN 3352-2
mit innenliegender, nichtsteigender Spindel
mit Anzeigevorrichtung

- Baulänge nach EN 558-1 Reihe 4 (DIN 3202)
- Flanschbohrungen nach DIN PN 10

Gate Valve Flat Body PN 10/16

nodular cast iron/stainless steel, DIN 3352-2
with inside, non rising stem
with position indicator

- face to face acc. to EN 558-1 serie 4 (DIN 3202)
- flange drilling acc. to DIN PN 10

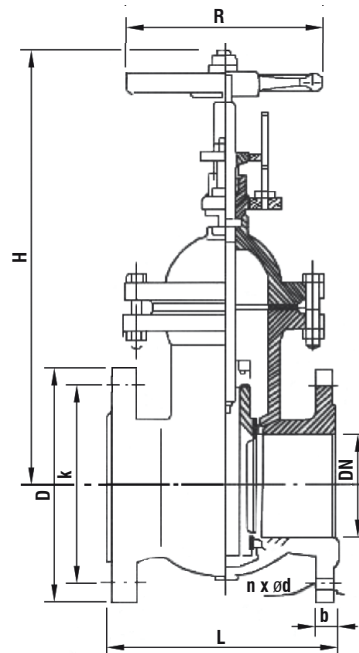

AW-Nr. AW no.	Pos. item	Bezeichnung denomination	Werkstoff material	nach DIN EN acc. to DIN EN	Werkstoff-Nr. material no.
145	1	Gehäuse / body	Sphäroguss / nodular cast iron	EN-GJS-400-18U-L-T	EN-JS1049
	2	Oberteil / bonnet	Sphäroguss / nodular cast iron	EN-GJS-400-18U-L-T	EN-JS1049
	3	Sitze / seats	Edelstahl / stainless steel	X20Cr13	1.4021
	4	Spindel / stem	Edelstahl / stainless steel	X20Cr13	1.4021

DN	L	H	D	b	Øk	n x Ød	R	≈ kg
40	140	265	150	18	110	4 18	140	11
50	150	270	165	20	125	4 18	140	13
65	170	295	185	20	145	4 18	160	17
80	180	325	200	22	160	8 18	160	20
100	190	365	220	24	180	8 18	200	28
125	200	440	250	26	210	8 18	200	40
150	210	490	285	26	240	8 22	200	50
200	230	610	340	26	295	8 22	250	85
250	250	730	395	26	350	12 22	315	135
300	270	870	445	28	400	12 22	315	180

**Betriebsdrücke und Temperaturen nach DIN 2401/
 working pressure and temperatures acc. to DIN 2401**