

Füll-/ Entleerungshahn PN 16

Rotguss, Schwermotdel - DIN 3848
 mit Stopfbuchse, Kappe und Kette

- Gewindezapfen nach DIN ISO 228

Fill and Drain Cock PN 16

gunmetal, heavy type - DIN 3848
 with gland, cap and chain

- male thread acc. to DIN ISO 228

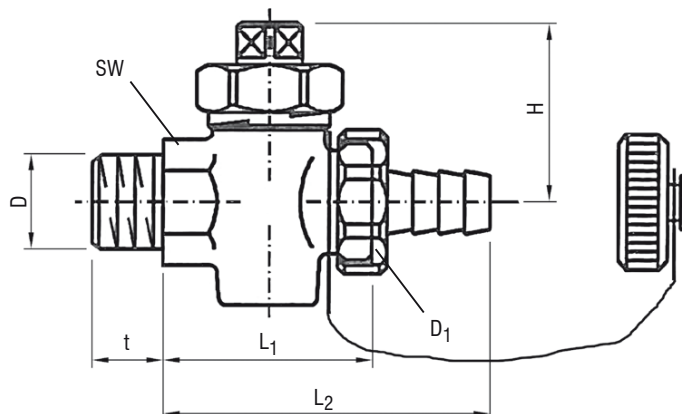

AW-Nr. AW no.	Pos. item	Bezeichnung denomination	Werkstoff material	nach DIN EN acc. to DIN EN	Werkstoff-Nr. material no.
418	1	Gehäuse / body	Rotguss / gunmetal	CuSn5Zn5Pb2	CC499K
	2	Kugel / ball	Rotguss / gunmetal	CuSn5Zn5Pb2	CC499K
	3	Stopfbuchse / gland	PTFE-Graphit-Compound		
	4	Schlauchverschraubung / hose coupling	Messing / brass		

DN	D	D ₁	L ₁	L ₂	H	t	SW
10	R 3/8"	G 1/2"	40,5	79	39	12	22
15	R 1/2"	G 3/4"	47,5	89	41	15	24
20	R 3/4"	G 1"	53,5	102	46	17	27
25	R 1"	G 1 1/4"	62,5	128	60	20	36

Verwendung

Flüssigkeiten, Dampf, aufbereitetes Heizungswasser
 (z.B. Fernheizungsanlagen)

Application

Liquids, steam, purified heating water
 (e.g. district heating system)

Temperatur t _s / temperature t _s	0°C bis / up to +150°C
kurzzeitig bis in the short therm up to	+180°C

AW 1182	Hahnschlüssel / valve handle	
	DN 10 - DN 15 (L = 120)	DN 20 - DN 25 (L = 130)
	Art.-No. 5911820012 (SW 12)	Art.-No. 5911820014 (SW 14)